



KSUB

Control and monitoring unit

Valid from week of manufacture 05/2016 and software version 3.0

Description

The KSUB is a control and monitoring unit designed to control various types of fire/smoke dampers and fans in a flexible way. The KSUB can be connected to the KSUA, or as a completely stand-alone unit. There are two damper groups, each containing two dampers and 2 smoke detector groups. These units can then be grouped in 1 or 2 fire zones. Each damper group and detector group can be monitored individually. A ventilation system can also be connected to the KSUB for locking. The KSUB has an input for an external fire alarm and for night mode. KSUB light is a version designed for dampers only. KSUBx is for smoke exhaust.

General

- Slave unit for KSUA
- 3 versions. KSUB light for dampers only and KSUBx for smoke exhaust.
- Can be used as a stand-alone unit
- 2 damper groups, 4 dampers
- 2 detector groups
- Built-in locking of fans
- 48-hour clock for damper exercises
- External input for central fire alarm system
- Night mode input
- Damper position indication
- Integrated transformer
- Many selectable options
- Jackable terminals

Maximum configuration

The system can handle a total of two damper groups with a maximum of four dampers and two detector groups. In principle, an unlimited number of smoke detectors can be connected.

These smoke detector groups and fire dampers can then be grouped into a maximum of two fire zones. 1 output for fan control



Installation

Designed for wall installation

Supply voltage

230 VAC 50 Hz 30VA. Protected with 2A at least.

Protection class

IP66

Ambient temperature

Max +35°C, min -10°C.

Weight

1.5 Kg

Outputs

- Sum alarm. Voltage-free changeover contact 8A max 250V. Terminal numbers 10,11,12.
- Triggered smoke detector, shared by all fire zones. Voltage-free changeover contact 8A max 250V. Terminal numbers 7,8,9.
- FAN 1. Voltage-free changeover contact max 8A / 250V. Terminal numbers 13,14,15.
- Damper group 1.
- Damper group 2.

Inputs

- Bus for KSUA and SUSA master unit (RS485)
- Terminals 1,2. Switchable between External control unit and Night mode. For example, opening the circuit has the same

ON Control AB, Stationsvägen 2, 516 31 Dalsjöfors, Sweden

Tel:+46 33 25 65 70, Mobile: +46 70 625 86 00.

www.oncontrol.se

effect as a triggered smoke detector (both groups affected)

- Detector 1. Terminals 3,4

- Detector 2. Terminals 5,6
- Input for 230V 50Hz

Size

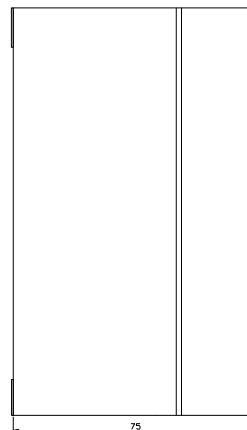
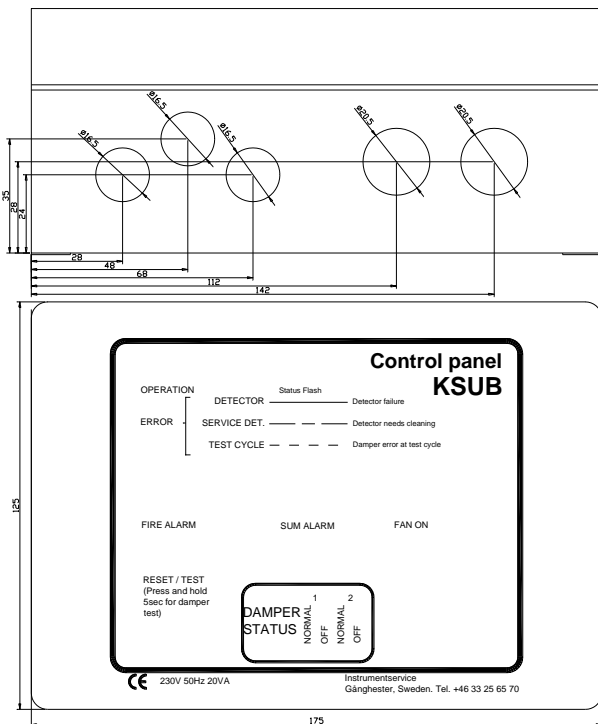

KSUB in network operation

(Jumper H off)

The KSUB will only work in a network if the KSUA has been correctly installed. To communicate, the KSUA and KSUB use a communication protocol which, at level 1, is based on RS485. The physical connections are two-wire links which must also have a ground. In other words, the units must be linked with three wires. Experience shows that the system often works with just two wires, with some installers even claiming that it works better with two wires than with three. What is important, however, is to make sure the network is connected correctly. If a number of KSUBs are connected to the KSUA, the first and last units must be terminated by closing jumper I in the KSUB or jumper PL2 in the KSUA. Sometimes, the KSUA is between other units, and in this case both the terminations are in KSUBs. Note that there cannot be more than two terminations in the whole network. The maximum line length is 1200m without repeater.

Address

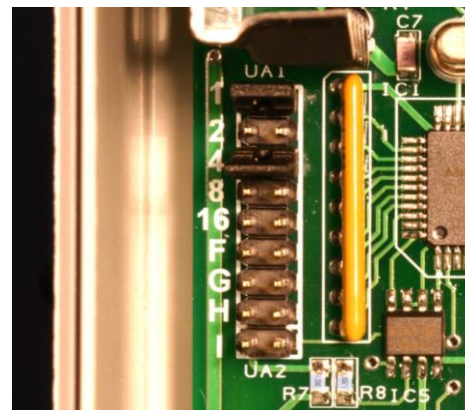

Picture with Address 5 configured.

A KSUB will only work in the network if an address is defined. The jumpers numbered 1,2,4,8 and 16 are used to set the address. For example to use address 15, close jumpers 1,2,4 and 8 (1+2+4+8=15). You cannot use the same address for two units within the same network. The addresses go from 0 to 31. To set address 0, leave all positions 1,2,4,8 and 16 empty. Dampers and detectors are counted from address 0 upwards. For example address 0 DMP1+2. Address 1 DMP3+4. Address 3 DMP5+6, etc. (2 damper groups per address)

Jumpers used in network operation:

| Jumper | On | Off |
|------------|--|---|
| 1,2,4,8,16 | Address | |
| F | Start of local fan controlled by EXT input (terminals 1 and 2) | EXT input used for Fire Alarm Logically connected to Det1 |
| G | Force KSUA to daytime mode when EXT is shorted | |
| H | Stand-alone mode | Network mode |

Fan control

In network mode, the fan output can be used to control a local fan. If you connect a timer to input 1,2 you can control the dampers (jumper F) connected to this particular KSUB and also start a local fan via 13,14,15. This function could be used in a meeting room, for example, to run forced ventilation on the basis of a local timer. This function can also act on the centrally controlled ventilation system, and works by starting day mode, opening the dampers, then starting and running the ventilation system while the timer is counting down. This function only works if jumpers F and G are on.

If you are just using damper group 1, fan control will only work if G and O are jumpered in damper group 2.

Smoke detectors

The smoke detectors are connected to the KSUB and are then operated by the KSUA in detector groups, which in turn control the dampers. The EXT input is logically connected to detector input 1. This means the EXT input can be used for a heat detector, for example, or an external central fire alarm system that can be configured to be part of a detector group.

When you perform a reset on the KSUA all detectors are switched off for 5 seconds to reset them.

Malfunctions.

If a communication error occurs, the KSUB will take over and close the dampers after 15 seconds.

Other errors are forwarded to the KSUA for central processing.

LEDs

Every time a correct message is received, the Operation LED switches on or off in order to indicate that communication with the master is working correctly. The Error LED lights up if communication stops. Other LEDs work in the same way as in stand-alone mode.

Buttons

No function in network mode.

Stand-alone mode

(Jumper H on)

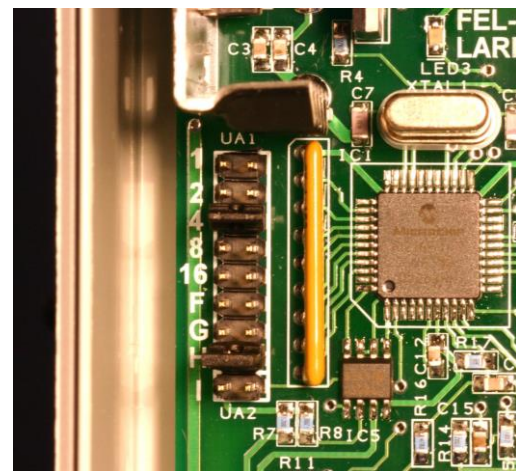

Picture shows jumper H and 4 on. (Stand-alone mode and only damper 1 in use.)

Priority handling

If an alarm (triggered detector or external fire alarm) is received during the function test, the test is ended and the unit immediately switches to alarm state.

Function test

The function test is carried out 10 hours after power is connected to the KSUB, and then every 48 hours. This means you can run the function test at night without having to switch on the unit during night-time installation. In night mode, the function test can be run without special programming. The KSUB detects the damper positions and carries out the function test in the other direction.

Manual function test

To carry out a manual function test, hold down the relevant reset button for longer than five seconds. After five seconds, the Operation and Alarm LEDs stop alternating. The test starts when you release the button.

Fan control

Intelligent and integrated fan control is provided. There are various options for the fan control output. If the ventilation system is connected, the fan receives the stop signal as soon as smoke is detected. For controlled, non-acute operation, for example in a function test, the fan is given 30 seconds to reduce its speed before any damper is closed.

Various jumper settings can be used to prevent fan locking.

Fan control in stand-alone mode.

| Jumper | On | Off |
|--------|--------------------------------|-----------------------------|
| 2 | Do not stop fan at night | Stop fan at night |
| 16 | Do not stop fan at damper test | Stop fan at damper test |
| F | No delay after fan stop | 30 sec delay after fan stop |

Selectable options

The table below shows the jumper settings that can adjust the function of the unit. The jumper panel is on the left.

Description of jumpers.

Overview of jumpers

| Jumper | On | Off |
|--------|------------------------------------|------------------------------------|
| 1 | Terminals 1-2 are night mode input | Terminals 1-2 are Fire Alarm input |
| 2 | Do not stop fan at night | Stop fan at night |
| 4 | Damper SPJ2 is not in use | Both dampers are in use |
| 8 | 2 Fire zones | 1 Fire zone |
| 16 | Do not stop fan at damper test | Stop fan at damper test |
| F | No delay after fan stop. | 30 sec delay after fan stop |
| G | Test dampers in sequence | Test both dampers simultaneously |
| H | Stand-alone operation | Network operation |
| I | IsBus termination ON | IsBus termination OFF |

Notes

1=ON

Determines whether the EXT input is used to connect the external fire alarm system (alarm) or to close the dampers (Night mode). OFF means that if the EXT input circuit is opened, the effect is the same as if a detector had triggered. This affects zones 1 and 2 simultaneously. ON means that if the EXT input circuit is opened, the system switches to night mode (the EXT input is normally jumpered).

8=ON

Connects detector input 1 to damper group 1 and detector 2 to damper group 2. The KSUB now acts as two separate units – for example only damper group 1 is operated if smoke detector 1 is triggered. Damper

group 2 remains active as long as detector input 2 is not triggered. However, fans are stopped as soon as either of the detector inputs is triggered.

16=ON

Means that the fans are not stopped for a function test. Use this setting if the unit is operating at the periphery of a ventilation system. Note that high pressure can build up in the duct system if this jumper is on, because the monitored/controlled dampers are located in the main duct.

G=ON

Used to carry out the function test on one damper group at a time. Group 1 is tested first, followed by group 2.

Parallel connection of dampers

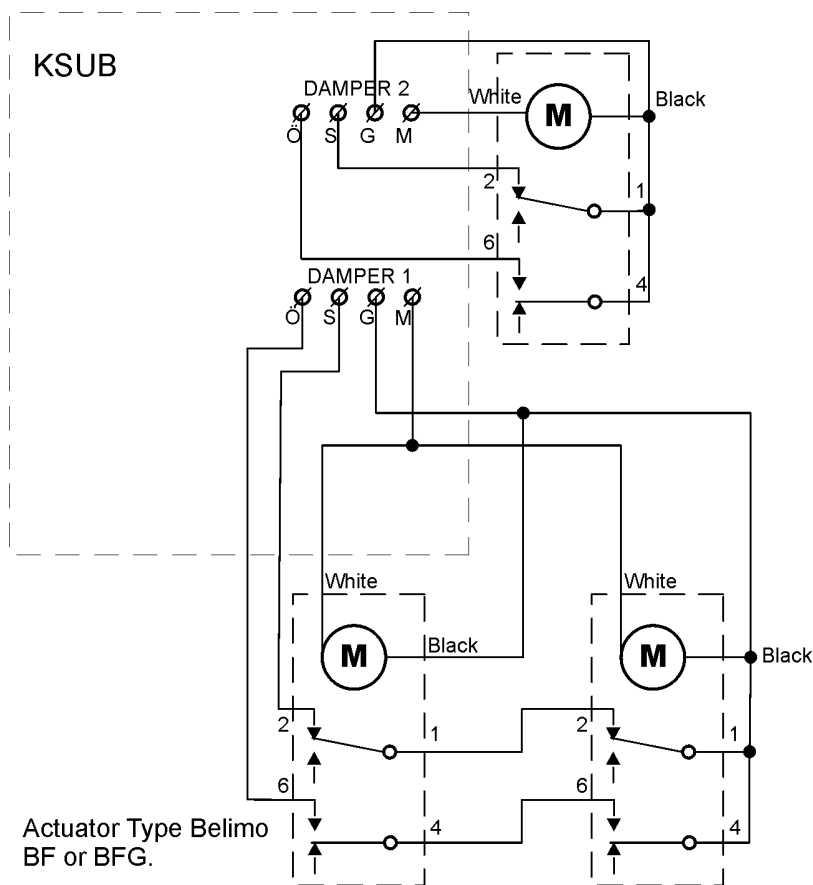

Parallel connection of damper at connection DAMPER 1 and single connection at DAMPER 2.

Smoke detector inputs

The two smoke detector inputs are designed for a loop resistance of 2200 ohm (terminating resistor). Depending on the setting of jumper 8, one or both detector circuits are connected. Unused detector inputs are terminated with a resistor connected directly to the terminal. 2200 ohm, power at least 1W. See also the description of jumper settings.

KSUB Light

KSUB Light just has connections for dampers, EXT input and network. Otherwise it works like a fully-featured KSUB. For the network, the smoke detector inputs are simulated so they are always in the normal state.

KSUBx.

KSUBx Is loaded with a different software than standard. In network mode it works exactly as the normal KSUB. KSUBx terminal

13-14-15 is intended for smoke exhaust fan connection and the damper connections is for evacuation dampers. The KSUBx is controlling both dampers and exhaust fan like this: If a detector indicates smoke the damper(s) is opening and after either damper is fully open or after 30 s. (selectable) the fan is starting. When reset the fan is stopped and the damper(s) are closing.

| Jumper | ON | OFF |
|--------|-------------------------------------|---|
| 1 | Automatic reset of ext. Fire Alarm. | Manual reset |
| 2 | Start fan after 30s | Start fan when damper is fully open (OFF) |
| 4 | Only damper 1 | Damper 1 & 2 |
| 8 | 2 fire zone | 1 fire zone |
| G | Test of dampers in sequence | Both dampers tests in parallel. |

Only valid for KSUBx in stand-alone mode.

Cable type for connections

The smoke detectors are connected with twisted-pair cable separated from other parts. Telephone type cable is used, with no particular requirements in terms of area.

For example, the actuator can be connected with EKKX 1*4*0.5 if the distance between the actuator and the KSUB is less than 100 metres. If the distance is greater, a larger area is required, especially for the G wire but also for M. DC resistance must not exceed 8 ohm.

Understanding and use

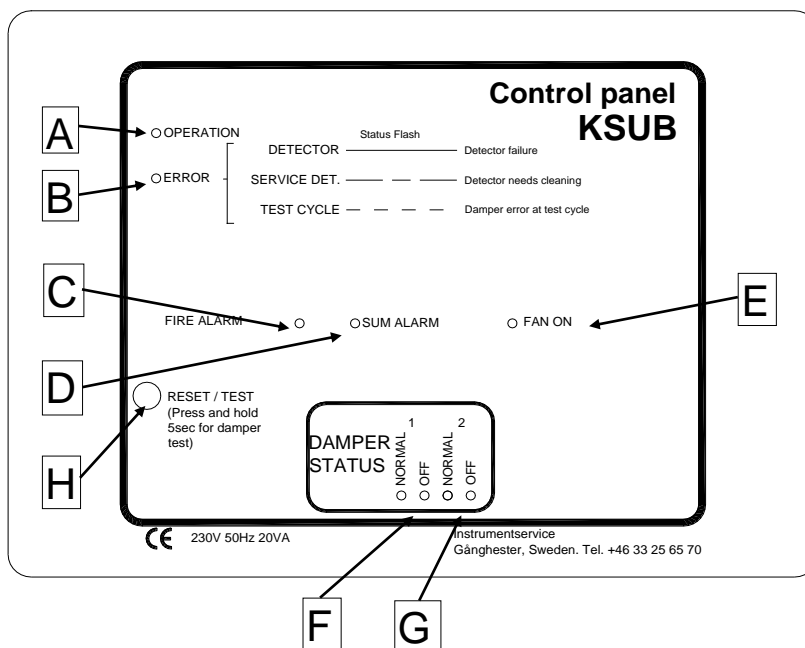

Indicators and buttons

A. Operation

Green LED showing that the unit is receiving power and indicating day/night mode. Constant = day mode. Flashing = night mode.

B. Error

This LED uses three different flashing sequences to indicate three different alarms.

- Constant if the detector loop is broken.
- Alternating short and long flashes to indicate a service alarm (dirty smoke detector). The indication is delayed by one hour to prevent false alarms. When the alarm is reset, the delay is deactivated to make it possible to confirm immediately that the alarm has been cleared.
- Rapid flashes if the 48-hour test fails. The following are tested for errors.

Fuses

There is a 160mAT fuse on the motherboard. The fuse is to the right of the mains transformer. The holder is the bayonet type. To remove the fuse, press down and turn a quarter turn anticlockwise.

- The dampers in both damper groups close within 30 seconds.
- The actuator contacts are correctly closed with the dampers in the closed position.
- The dampers open within 200 seconds.
- The actuator contacts are closed with the damper in the open position.

C. Triggered smoke detector

The same LED covers both smoke detector loops. If the LED is red, a detector has been triggered. The associated relay is closed.

D. Sum alarm

The sum alarm is indicated by the red LED and the associated relay output is closed when the following events occur:

- Break in any of the cable loops.
- Error during function test.
- Service alarm in any of the detector loops.

- Damper in incorrect position during normal operation.
- Connection error.

E. Fan on

Fan control is indicated with an LED that lights up when the relay is closed.

F. Reset/test

Button to reset the entire alarm. While the button is pressed, the detector outputs are disconnected to allow any triggered smoke detectors to be reset.

If you Keep the button pressed for at least 5 seconds, the function test starts when you release the button. After five seconds, the Operation and Alarm LEDs stop alternating and the Operation LED lights up instead. (The function test is usually initiated by the timer every 48 hours)

F and G. Dampers

The green and red LEDs indicate the normal position/alarm position respectively for the relevant damper. The normal position is open for a ventilation damper and closed for an evacuation damper.

The damper groups are numbered 1 and 2.

Troubleshooting

"ERROR" LED lights or flashes.

- Look at the pattern of flashing to identify the error.

If the LED is constantly lit, there is a break in the detector loop.

Check:

- The terminating resistor in the last detector of the loop with the problem. It should be 2200 ohm, 1W.
- If the input is not used, a resistor of 2200 ohm must be installed to replace the detectors.
- Break in cable
- Loose contact in the detector bases.
- Check the connections to the detectors.
- Polarity!

Alternating short and long flashes indicate a service alarm (dirty smoke detector)

Check:

- For dirt on one or more detectors. Indicated by a yellow LED on the affected detector if the detector has a service alarm function. Vacuum-clean or, in the worst case, replace the detector head.

Rapid flashes if the 48-hour test fails.

Check:

- That the right number of dampers are connected for the selected mode. If only one damper is used, it must be connected to DMP1 and jumper 4=On.
- That the dampers open and that the green LED is normal.
- Carry out a manual function test and check that the dampers operate within 30 seconds. The red LED lights up. The dampers must then return to the normal position within 200 seconds and the green LED lights up.
- That the dampers are correctly connected. In particular, take care that G and M are not the wrong way round.

"FIRE ALARM" LED lights.

Check:

- That the EXT input is jumpered or closed by an external control unit.
- For a short-circuit in one of the detector loops.
- An alarm from a detector is indicated with an LED on the detector.

"SUM ALARM" LED lights.

Check:

- For other alarms indicated by the LEDs.
- That no damper has operated incorrectly.
- That the dampers are correctly connected. In particular, take care that G and M are not the wrong way round.

The dampers do not open.

Check:

- That there are no other alarms on the front panel.
- That the damper motor is connected correctly.

A manual reset is required after an automatic function test

The "fan lock" output has probably been connected to the wrong input in the ventilation system, which has locked itself as a result.

A manual reset is required after night mode.
Requires night mode signal from ventilation system to the KSUB.
Locking may occur if night mode is indicated by the KSUB, which then sends a stop signal

to the system via fan lock. This locking may be bypassed by setting jumper 2. The fans are still locked if a smoke detector is triggered and during the function test.

Disposal of old Electrical & Electronic Equipment (Applicable throughout the European Union and other European countries with separate collection programs)

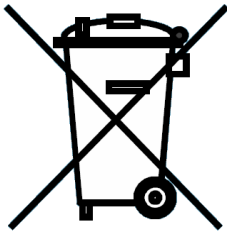

This symbol, found on your product or on its packaging, indicates that this product should not be treated as household waste when you wish to dispose of it. Instead, it should be handed over to an applicable collection point for the recycling of electrical and electronic equipment. By ensuring this product is disposed of correctly, you will help prevent potential negative consequences to the environment and human health, which could otherwise be caused by inappropriate disposal of this product. The recycling of materials will help to conserve natural resources. For more detailed information about the recycling of this product, please contact your local city office, household waste disposal service or retail store where you purchased this product.